

BALDOR® • RELIANCE 

Product Information Packet

ZDM3665T

5HP, 1750RPM, 3PH, 60HZ, 184TC, 0640M, TEBC, F1

Part Detail							
Revision:	Z	Status:	PRD/A	Change #:		Proprietary:	No
Type:	AC	Elec. Spec:	06WGW352	CD Diagram:	CD0005	Mfg Plant:	
Mech. Spec:	06F552	Layout:	06LYF552	Poles:	04	Created Date:	
Base:	RG	Eff. Date:	05-05-2015	Leads:	9#16		

Specs			
Catalog Number:	ZDM3665T	Insulation Class:	H
Enclosure:	TEBC	Inverter Code:	Inverter Duty
Frame:	184TC	KVA Code:	J
Frame Material:	Iron	Lifting Lugs:	Standard Lifting Lugs
Output @ Frequency:	5.000 HP @ 60 HZ	Locked Bearing Indicator:	Locked Bearing
Synchronous Speed @ Frequency:	1800 RPM @ 60 HZ	Motor Lead Quantity/Wire Size:	9 @ 16 AWG
Voltage @ Frequency:	230.0 V @ 60 HZ	Motor Lead Exit:	Ko Box
	460.0 V @ 60 HZ	Motor Lead Termination:	Flying Leads
XP Class and Group:	None	Motor Type:	0640M
XP Division:	Not Applicable	Mounting Arrangement:	F1
Agency Approvals:	UR	Power Factor:	80
	CSA	Product Family:	General Purpose
Auxillary Box:	No Auxillary Box	Pulley End Bearing Type:	Ball
Auxillary Box Lead Termination:	None	Pulley Face Code:	C-Face
Base Indicator:	Rigid	Pulley Shaft Indicator:	Standard
Bearing Grease Type:	Polyrex EM (-20F +300F)	Rodent Screen:	None
Blower:	BLOWER	Shaft Extension Location:	Pulley End
Current @ Voltage:	13.000 A @ 230.0 V	Shaft Ground Indicator:	No Shaft Grounding

	6.500 A @ 460.0 V	Shaft Rotation:	Reversible
Design Code:	B	Shaft Slinger Indicator:	No Slinger
Drip Cover:	No Drip Cover	Speed Code:	Single Speed
Duty Rating:	CONT	Motor Standards:	NEMA
Electrically Isolated Bearing:	Not Electrically Isolated	Starting Method:	Direct on line
Feedback Device:	ENCODER	Thermal Device - Bearing:	None
Front Face Code:	Encoder/Feedback Device	Thermal Device - Winding:	Normally Closed Thermostat
Front Shaft Indicator:	None	Vibration Sensor Indicator:	No Vibration Sensor
Heater Indicator:	No Heater	Winding Thermal 1:	None
		Winding Thermal 2:	None

Nameplate NP1167L	
CAT NO	ZDM3665T
SPEC.	06F552W352Z1
FRAME	184TC HP 5 TE
VOLTS	230/460
MAG CUR	6.8/3.4 FLA 13/6.5
RPM	1750 RPM MAX 6000
HZ	60 PH 3 CLASS H
SER.F.	1.00 DES B SL HZ 1.7
NEMA-NOM-EFF	90.2 WK2 0.37
BLWR V	115 PH 1 HZ 60 A .26
RATING	40C AMB-CONT
DE BRG	6206 ODE BRG 6205
CC	010A SN

Parts List		
Part Number	Description	Quantity
SA056378	SA 06F552W352Z1	1.000 EA
RA050934	RA 06F552W352Z1	1.000 EA
HW3201A05	3/8-16 EYEBOLT	1.000 EA
06CB3000	BALDOR CONDUIT BOX CAST	1.000 EA
06GS1000	GASKET,CONDUIT BOX	1.000 EA
51XW2520A12	SCREW, HEX SER SLT HD, ZN, 1/4-20 X .75	2.000 EA
51XW2520A12	.25-20 X .75, TAPTITE II, HEX WSHR SLTD	2.000 EA
11XW1032G06	10-32 X .38, TAPTITE II, HEX WSHR SLTD U	1.000 EA
HW3001B01	BRASS CUP WASHER, FOR #10 SCREW	1.000 EA
36EP1101B41	FR TEBC 205 BRG W/ GR SR & THRU-SHAFT ENC	1.000 EA
HW4500A01	1641B(ALEMITE)400 UNIV, GREASE FITT	1.000 EA
HW5100A05	WVY WSHR F/205 & 304 BRGS	1.000 EA
36PE1300A01	PU ENDPLATE, MACH	1.000 EA
HW4500A01	1641B(ALEMITE)400 UNIV, GREASE FITT	1.000 EA
10XN2520A26	1/4-20X 1 5/8 HEX HD	4.000 EA
HW1001A25	LOCKWASHER 1/4, ZINC PLT .493 OD, .255 I	4.000 EA
HA3101A34	THRUBOLT- 1/4-20 X 10.375	4.000 EA
10XN2520A08	1/4-20X1/2 HEX HEAD CAP	1.000 EA
HA3218A05	M/FE STANDOFF UNIC#SX1043.25-20 .38 HEX	3.000 EA
10XN2520A06	1/4 20X3/8 HX HD CAP	3.000 EA
HW1001A25	LOCKWASHER 1/4, ZINC PLT .493 OD, .255 I	3.000 EA
06CB3500	BALDOR CONDUIT BOX LID	1.000 EA
06GS1001	BALDOR CONDUIT BOX GASKET	1.000 EA
HA1005A03SP	SLINGER, OD 1.750, ID .938, 205 BRG	1.000 EA

Parts List (continued)		
Part Number	Description	Quantity
HW2501E16	KEY, 1/4 SQ X 1.750	1.000 EA
HA7000A02	KEY RETAINER RING, 1 1/8 DIA, 1 3/8 DIA	1.000 EA
MJ5004A05	#242-21 LOCTITE GENERAL PURPOSE MED. STR	0.005 EA
85XU0407S04	4X1/4 U DRIVE PIN STAINLESS	2.000 EA
LB1115N	LABEL,LIFTING DEVICE (ON ROLLS)	1.000 EA
LB1009N	LABEL,ROTATION DIRECTION (ON ROLLS)	1.000 EA
MJ1000A02	GREASE, MOBIL POLYREX EM - 124047	0.050 LB
06FH5001A01	BLOWER ASSY. 06FH4001, EF0001	1.000 EA
MG1000G27	MED CHARCOAL METALLIC GREY 400-0096	0.028 GA
LC0035B01	1PH, SV, FIX, 2 LEAD	1.000 EA
OE5011A04	HS25 ENCODER ASSY - TEBC	1.000 EA
LB1119N	WARNING LABEL	1.000 EA
LC0145B01	CONNECTION LABEL	1.000 EA
NP1167L	SS VEC UL CSA CC	1.000 EA
G0PA1000	PKG GRP, PRINT PK1026A06	1.000 EA
MN416A01	TAG-INSTAL-MAINT no wire (1200/bx) 3/19	1.000 EA



AC Induction Motor Performance Data

Record # 20655

Typical performance - not guaranteed values

Winding: 06WGW352	Type: 0640M	Enclosure: TEFC
--------------------------	--------------------	------------------------

Nameplate Data			General Characteristics at 460 V, 60 Hz: High Volt Connection		
Rated Output (HP)	5		Full Load Torque	15 LB-FT	
Volts	230/460		Start Configuration	DOL	
Full Load Amps	13/6.5		Break Down Torque	50 LB-FT	
R.P.M.	1750		Pull-Up Torque	30 LB-FT	
Hz	60	Phase	3	Locked-rotor Torque	32 LB-FT
NEMA Design Code	B	KVA Code	J	Starting Current	48 Amps
Service Factor	1.00		No-load Current	3.4 Amps	
NEMA Nom. Eff.	90.2	P.F.	80	Line-line Res. @ 25°C.	2.61 Ohms
Rating - Duty	40C AMB-CONT		Temp. Rise @ Rated Load	47°C	
S.F. Amps			Temp. Rise @ S.F. Load		

Load Characteristics at 460 Volts, 60 Hz, 5 HP

	25	50	75	100	125	150	S.F.
% of Rated Load	25	50	75	100	125	150	S.F.
Power Factor	39	61	75	82	86	88	
Efficiency	84.1	89.4	90.4	90.2	89.4	88.3	
Speed	1789	1778	1767	1755	1742	1729	
Line Amperes	3.6	4.3	5.2	6.4	7.2	9	

Baldor Electric Company Fort Smith, Arkansas



Catalog	ZDM3665T	NIP VOLTS	230/460	ENCLOSURE	TEBC	WYE CONNECTION OHMS PER PHASE (BASE RATING, 200°)			
FRAME	184TC	NIP AMPS	13/6.5	Base Volts	460	R1	1.200	X1	2.786
HP	5 HP	DUTY	Cont	Base AMPS	6.4	R2	0.977	X2	2.177
BASE SPEED	1800	MAX SAFE RPM	6000	Slip Hz	1.50	XM1			78.683
PHASE/HZ	3/60	AMB ⁶ C/INSUL	40/H	WK ² (lb-ft ²)	0.372				

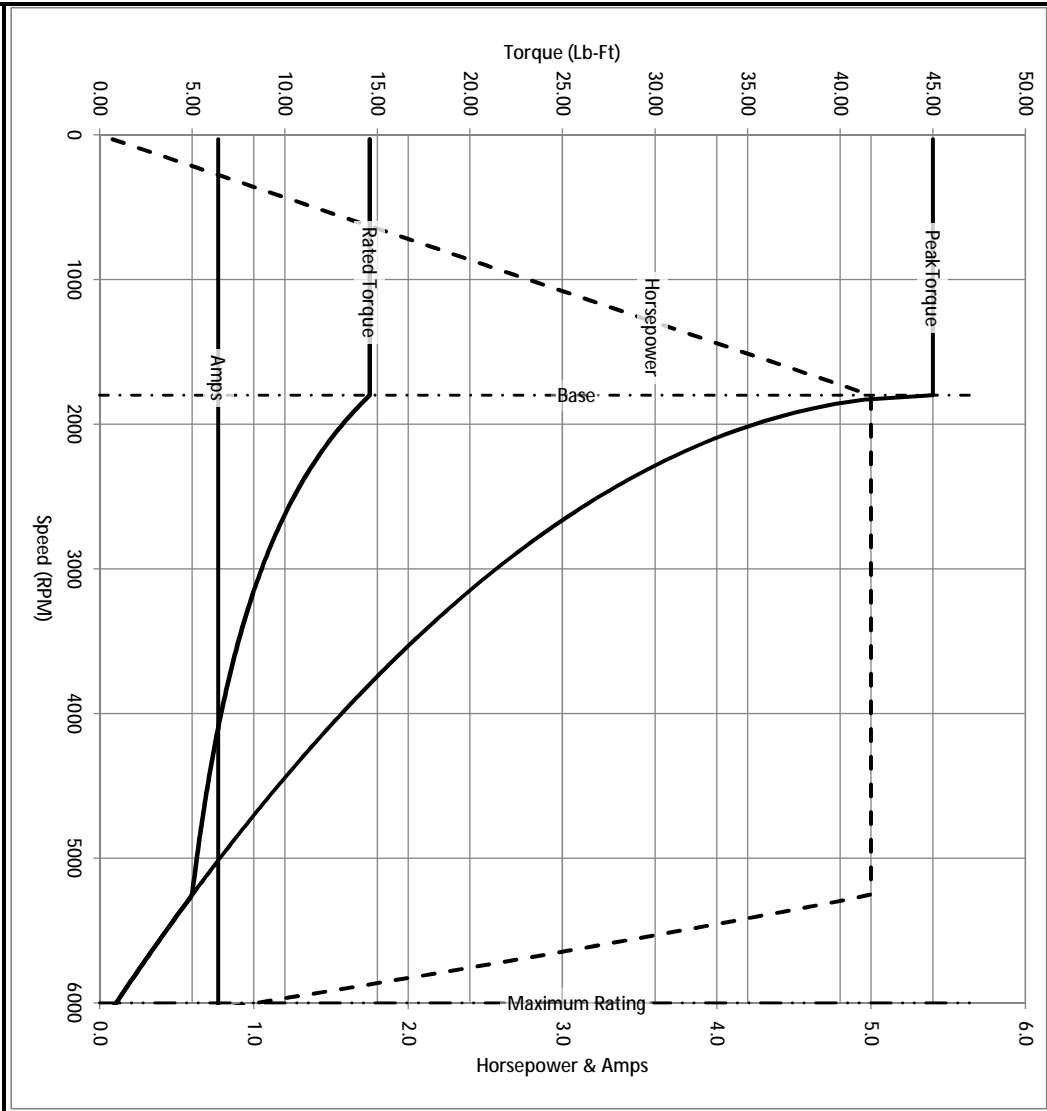

Remarks: Calculated Data

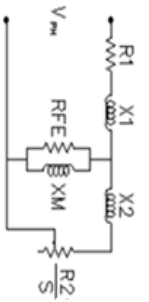

BALDOR DR BY ENR
 CK BY ENR
 APP BY ENR
 DATE 2/26/2013

A MEMBER OF THE ABB GROUP

A-C MOTOR PERFORMANCE CURVES

06F552W352Z1

ISSUE DATE 2/26/2013

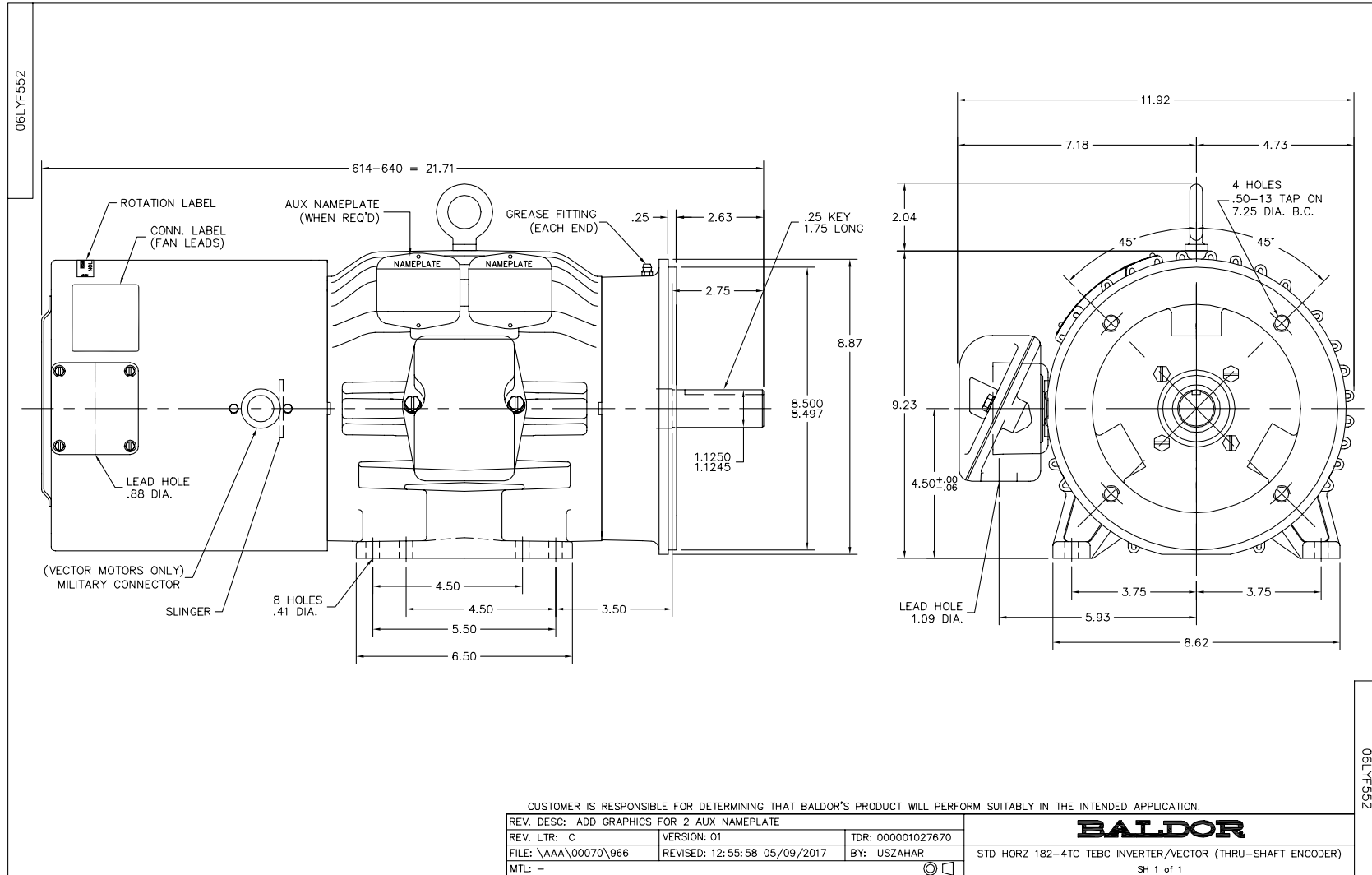

CD0005



LOW VOLTAGE
(2Y)



LINE

HIGH VOLTAGE
(1Y)



LINE

NOTES:

1. INTERCHANGE ANY TWO LINE LEADS TO REVERSE ROTATION.
2. OPTIONAL THERMOSTATS ARE PROVIDED WHEN SPECIFIED.
3. ACTUAL NUMBER OF INTERNAL PARALLEL CIRCUITS MAY BE A MULTIPLE OF THOSE SHOWN ABOVE.
4. LEAD COLORS ARE OPTIONAL. LEADS MUST ALWAYS BE NUMBERED AS SHOWN.

REV. DESC: REVISE TO SHOW OPTIONAL COLORS			
REV. LTR: E	BY: JLP	REVISED: 01/19/99 10:15	TDR: 0171435
90000		FILE: AAA00005140	MDL: -
		MTL: -	

BALDOR ELECTRIC Co.

3PH, DV, 9 LEADS

CD0005